

Guide for tilted socket

AAG series (10pcs/pack)

- Please use this when placing a heavy item on the slave board and when using a large slave board.
- This is also used for smoothly inserting to a tilted socket.
- Material
 - Resin part: PBT black (UL94V-0)
 - Pin part: Brass, Tin plating over nickel base
- Operating temperature range: - 40 to + 125°C
- Printed board fitting hole diameter: ϕ 1.6

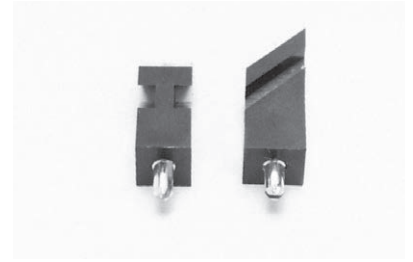

Part No.	A	PC board thickness
AAG-0.6	0.7	0.6
AAG-0.8	0.9	0.8
AAG-1.0	1.1	1.0
AAG-1.2	1.3	1.2
AAG-1.6	1.7	1.6

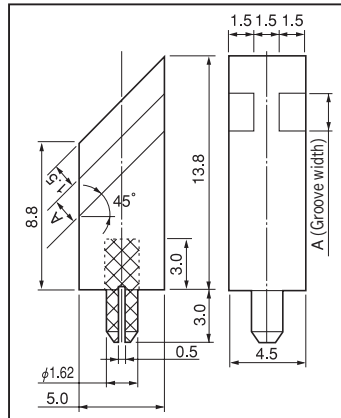

■ Example of usage

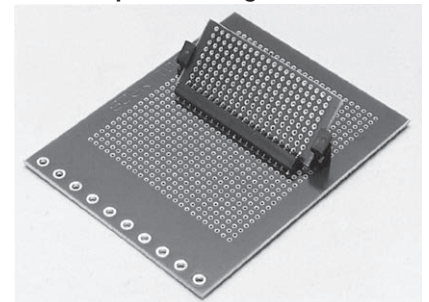

● Fitting dimension

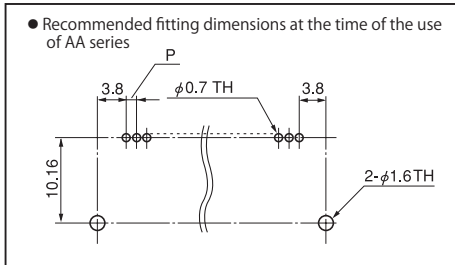

Male pin for AA series

MA- □ -0series (10pcs/pack)

- This is a male pin used for the slave board of AA series.
- Two types, of pitch (1.27mm and 2.54mm) are available.
- Material
 - Resin part: PCT black (UL94V-0)
 - Pin part: Phosphor bronze (Gold plating over nickel base)
- Rated current: 2A
- Insulation resistance: 500M Ω or over
- Withstand voltage: MA-1-0: 700V AC, DC per minute
MA-3-0: 1000V AC, DC per minute
- Operating temperature range: - 40 to + 125°C
- Printed board fitting hole diameter: ϕ 0.6

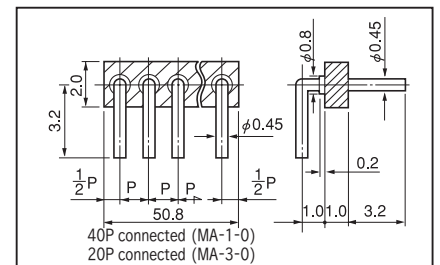
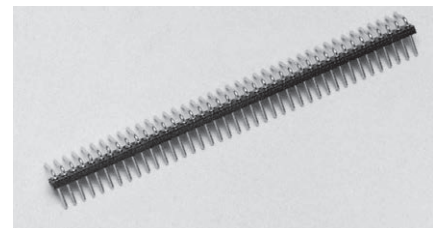

Part No.	P	Maximum number of poles connected
MA-1-0	1.27	40
MA-3-0	2.54	20

■ How to order:

MA-1-0-10P

↑ Please fill in the number of poles to use.
(If the number is not specified, we will deliver the part of the maximum number of connection.)

■ Fitting dimension

