

**Pressure contact terminal for electric wire for surface mounting**

**CN series**

- This terminal is for connecting and fixing electric wire to a surface mounting board.
- With the tape-and-reel, it can be automatically mounted by using a mounter.
- By using an exclusive jig for this purpose, electric wire can be connected without peeling the electric wire covering.
- Please use the mounter of automatic recognition type.
- Material: Phosphor bronze
- Finish: Gold plating over nickel base
- Adaptive electric wire: AWG22 UL STYLE 1007, CSA TYPE TR-64 (Stranded wire)
- Rated current: 3A
- Contact resistance: 30m Ω or less
- Tensile strength of electric wire: 14.7 N (1.5kgf) → 
- Operating temperature range: - 40 to + 90°C

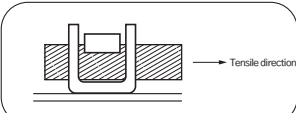
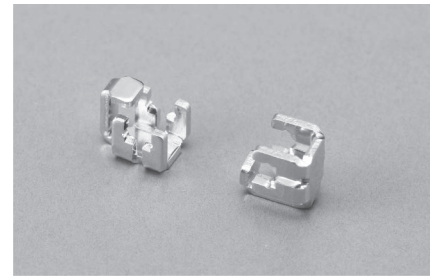

**Example of usage**

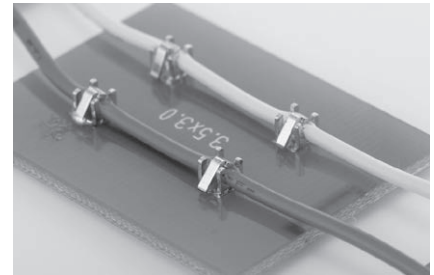

| Part No.  | Package            |
|-----------|--------------------|
| CN-5-22   | Reel (450pcs/reel) |
| CN-5-22-B | Bulk (100pcs/pack) |

**Dimension**

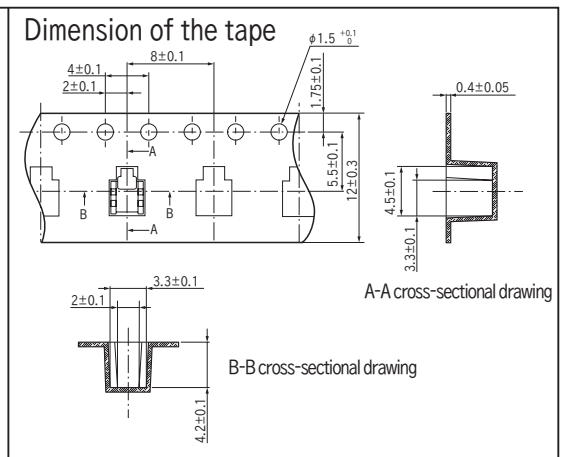
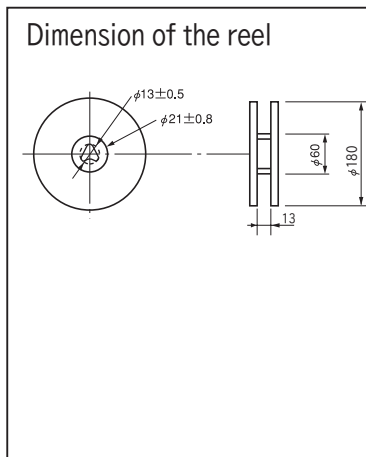
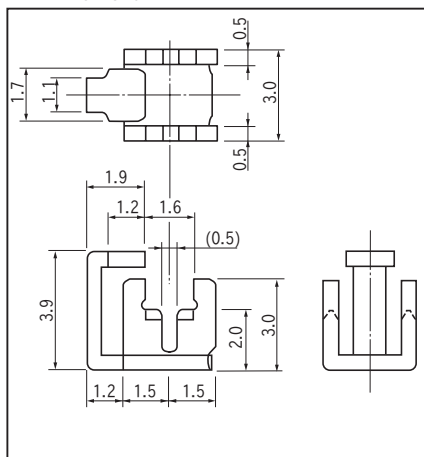

**Recommended land information**

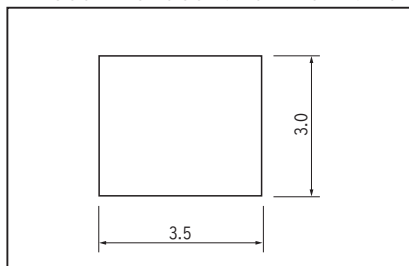

**Exclusive jig for pressure contact terminal for electric wire for surface mounting**

**CN-5-22-JIG**

Tool

- This jig is used for connecting and fixing the electric wire to the mounted CN-5-22. (1unit/pack)

**How to use**

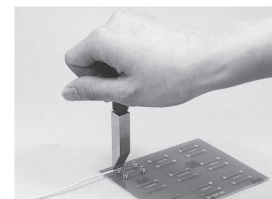
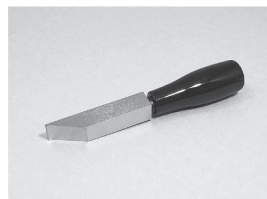

- The jig is subject to change without notice.

**Instructions**

- Please push the pressure contact jig slowly from the vertical direction to the deep part.
- After installing electric wire, it is impossible to remove and reconnect it.
- Any excessive forces applied to the electric wire connection part due to stretching or pulling of electric wire can cause contact failure. Please handle this state by allowing looseness for electric wire or taking other adaptive measures.