

Ultra-thin metal pipe

TB series (100pcs/pack)

- By using this pipe, thin stainless wire and other electric wires for which soldering is impossible can be fit on one side of the pipe by crimping and the other side can be soldered and fit on a PC board.
- This can be used for relaying thin wires by crimping.
- Material TB-4, TB-8: Phosphor bronze
TB-10, TB-14, TB-16, TB-22, TB-26, TB-28, TB-33: Brass
- Finish: Gold plating over nickel base

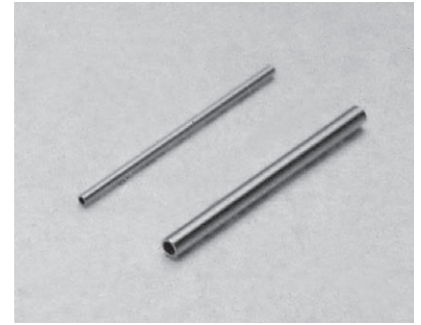

Part No.	A	B	L
TB-4-5	0.29	0.40	5
TB-4-8	0.29	0.40	8
TB-4-10	0.29	0.40	10
TB-8-5	0.53	0.76	5
TB-8-8	0.53	0.76	8
TB-8-10	0.53	0.76	10
TB-10-5	0.77	0.97	5
TB-10-8	0.77	0.97	8
TB-10-10	0.77	0.97	10
TB-10-15	0.77	0.97	15
TB-10-20	0.77	0.97	20
TB-14-5	1.08	1.38	5
TB-14-8	1.08	1.38	8
TB-14-10	1.08	1.38	10
TB-14-15	1.08	1.38	15
TB-14-20	1.08	1.38	20
TB-16-5	1.26	1.56	5
TB-16-8	1.26	1.56	8
TB-16-10	1.26	1.56	10
TB-16-15	1.26	1.56	15
TB-16-20	1.26	1.56	20
TB-22-8	1.57	2.17	8
TB-22-10	1.57	2.17	10
TB-22-15	1.57	2.17	15
TB-22-20	1.57	2.17	20
TB-26-8	1.97	2.57	8
TB-26-10	1.97	2.57	10
TB-26-15	1.97	2.57	15
TB-26-20	1.97	2.57	20
TB-28-8	2.20	2.80	8
TB-28-10	2.20	2.80	10
TB-28-15	2.20	2.80	15
TB-28-20	2.20	2.80	20
TB-33-8	2.68	3.28	8
TB-33-10	2.68	3.28	10
TB-33-15	2.68	3.28	15
TB-33-20	2.68	3.28	20

■ Example of usage

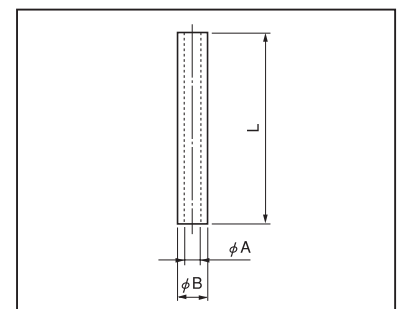
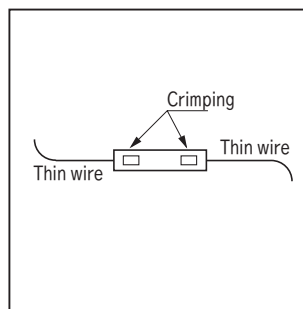
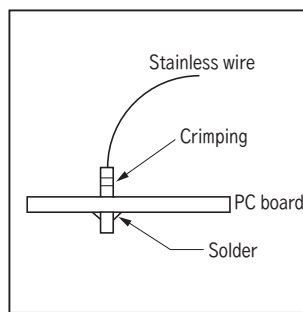
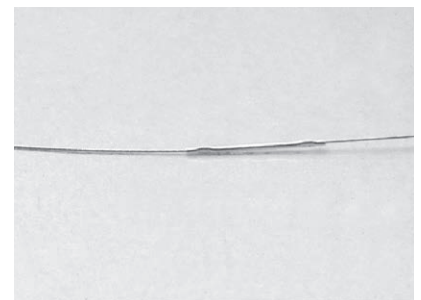
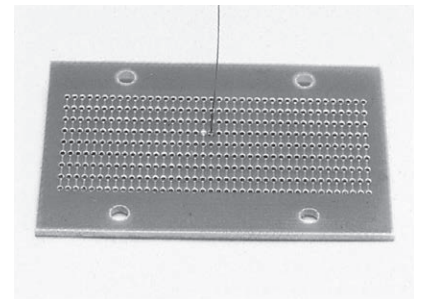

- * Crimping tool cannot be used for TB-4 and TB-8.
- * When carrying out crimping with TB-10, TB-14, TB-16 and TB-22 series, the crimping tool OMXT-1 can be used (please remove the fitting chip prior to use).
- * When carrying out crimping with TB-26, TB-28 and TB-33, the crimping tool OMXT-10 can be used.